

***XINGGUI***  
***Elliptical Cross Trainer***  
***ITEM NO.: 93040***

***LifeGear***  
Get active for life

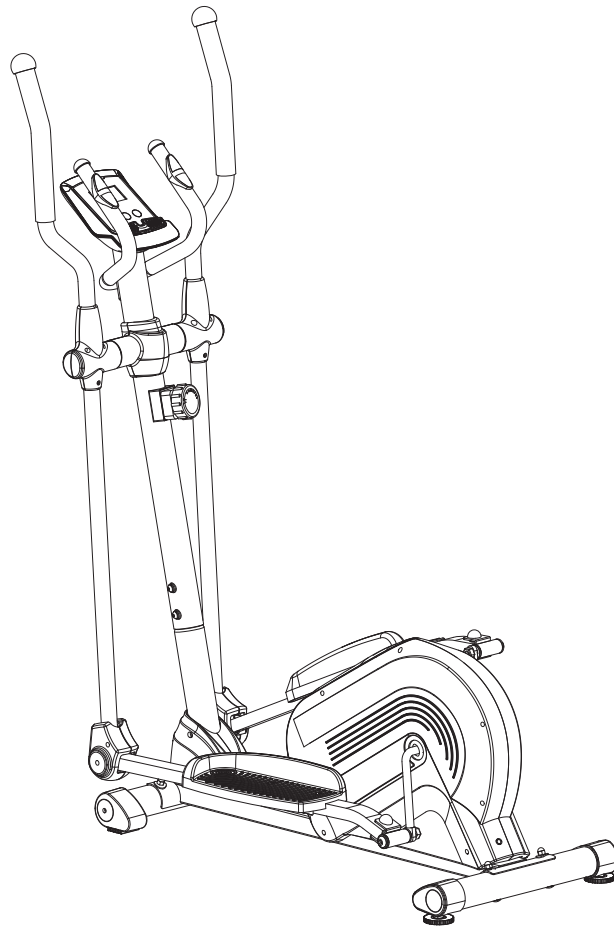

***OWNER'S MANUAL***

***IMPORTANT: Read all instructions carefully before using this product. Retain this owner's manual for future reference. The specifications of this product may vary from this photo and are subject to change without prior notice.***

# TABLE OF CONTENTS

|  |    |
|--|----|
| WARRANTY -----                           | 2  |
| IMPORTANT SAFETY INSTRUCTIONS -----      | 3  |
| PARTS LIST -----                         | 4  |
| TOOLS -----                              | 6  |
| HARDWARE LIST AND ASSEMBLY PART -----    | 7  |
| EXPLODED VIEW -----                      | 8  |
| ASSEMBLY INSTRUCTIONS -----              | 9  |
| HOW TO MOVE THE ELLIPTICAL TRAINER ----- | 26 |
| OPERATING THE COMPUTER -----             | 27 |
| ADJUSTMENTS -----                        | 29 |
| MAINTENANCE -----                        | 30 |
| TROUBLESHOOTING -----                    | 30 |
| WARM UP AND COOL DOWN ROUTINE -----      | 31 |

# ONE YEAR LIMITED WARRANTY

LifeGear Inc. warrants to the original purchaser that this product is free from defects in material and workmanship when used for the purpose intended, under the conditions that it has been installed and operated in accordance with LifeGear's Owner's Manual. LifeGear's obligation under this warranty is limited to replacing or repairing free of charge, any parts which may prove to be defective under normal home use. This warranty does not include any damage caused by improper operation, misuse or commercial application.

From the date of purchase, the frame is warranted to be free from defects for 1 (one) year.

This warranty is offered only to the original owner and is not transferable. Proof of purchase is required.

When ordering replacement parts please have the following information ready:

1. **Owner's Manual**
2. **Model Number**
3. **Description of Parts**
4. **Part Number**
5. **Date of Purchase**

# IMPORTANT SAFETY INSTRUCTIONS

Basic precautions should always be followed, including the following important safety instructions when using this equipment. Read all instructions before using this equipment.

1. Read all instructions and follow it carefully before using this equipment. Make sure the equipment is properly assembled and tightened before use.
2. Before exercise, in order to avoid injuring the muscle, warm-up exercises are recommended.
3. Please make sure all parts are not damaged and fixed well before use. This equipment should be placed on a flat surface when using. Using a mat or other covering material on the ground is recommended.
4. Please wear proper clothes and shoes when using this equipment; do not wear clothes that might catch any part of the equipment.
5. Do not attempt any maintenance or adjustments other than those described in this manual. Should any problems arise, discontinue use and consult your local dealer.
6. Be careful when step on or leave the pedal always hold the handlebars first. Make the pedal at your side at the lowest position, step on the pedal, and stride over the main frame then step on the other pedal. When using, please hold the handlebar by hands, make the pedals running smoothly by push or pull handlebars, then run the equipment regularly by cooperation of hands and feet. After exercise, please also make one pedal at the lowest position and leave your foot on the higher pedal first and then another.
7. Do not use the equipment outdoors.
8. This equipment is for household use only. It is not a commercial model.
9. Only one person at a time should use this equipment.
10. If you feel any chest pains, nausea, dizziness, or short of breath, you should stop exercising immediately and consult your physician before continuing.
11. Care should be taken in mounting or dismounting the equipment.
12. Do not allow children to use or play on the equipment. Keep children and pets away from the equipment while in use. This machine is designed for adults use only. The minimum free space required for safe operation is not less than two meters.
13. The maximum weight capacity for this product is 110 kgs.

**WARNING:** Before beginning any exercise program consult your physician. This is especially important for people who are over 35 years old or who have pre-existing health problems. Read all instructions before using any fitness equipment. Do not operate this exercise equipment without properly fitted guards, as the moving parts can present a risk of serious injury if exposed.

**CAUTION:** Read all instructions carefully before operating this product. Retain this Owner's Manual for future reference.

# PARTS LIST

| No.  | Description                                    | Qty | No.  | Description                                    | Qty |
|------|--|-----|------|--|-----|
| 001  | Main Frame                                     | 1   | 020  | U-Shape Bracket                                | 2   |
| 002L | Left Foot Bar                                  | 1   | 021  | Nylon Nut M8                                   | 2   |
| 002R | Right Foot Bar                                 | 1   | 022  | Washer Ø16xØ8x1.5T                             | 2   |
| 003L | Left Handrail Arm                              | 1   | 023  | Hexagon Head Bolt M8x45                        | 2   |
| 003R | Right Handrail Arm                             | 1   | 024  | Nylon Nut M6                                   | 10  |
| 004L | Left Handrail Ø32                              | 1   | 025  | Washer Ø6xØ12x1.0T                             | 7   |
| 004R | Right Handrail Ø32                             | 1   | 026  | Hexagon Head Bolt M6x40                        | 6   |
| 005  | Front Post                                     | 1   | 027  | Tension Cable L=1800 mm                        | 1   |
| 006  | Handlebar Ø28.6                                | 1   | 028  | Bolt Cap S13                                   | 2   |
| 007  | Front Stabilizer Ø60x1.5Tx480                  | 1   | 029  | Cross Recessed Pan Head Tapping Screw ST4.2x25 | 3   |
| 008  | Rear Stabilizer Ø60x1.5Tx480                   | 1   | 030A | Foot Bar Cover-A                               | 2   |
| 009  | Carriage Bolt M8x70                            | 4   | 030B | Foot Bar Cover-B                               | 2   |
| 010L | Front Left Transport Wheel Cap                 | 1   | 031  | Big Washer Ø6                                  | 2   |
| 010R | Front Right Transport Wheel Cap                | 1   | 032  | Bolt Ø15.8x62.5                                | 2   |
| 011  | Big Curve Washer Ø20xØ8                        | 10  | 033  | Left Foot Pedal 395x150x65                     | 1   |
| 012  | Cap Nut M8                                     | 4   | 034  | Right Foot Pedal 395x150x65                    | 1   |
| 013L | Bolt for left U-Shape Bracket<br>Ø16x88.5xL23  | 1   | 035  | Rear Left Stabilizer End Cap                   | 1   |
| 013R | Bolt for right U-Shape Bracket<br>Ø16x88.5xL23 | 1   | 036  | Rear Right Stabilizer End Cap                  | 1   |
| 014L | Left Nylon Nut 1/2"                            | 1   | 037  | Cover Cap Ø40xØ25x10                           | 2   |
| 014R | Right Nylon Nut 1/2"                           | 1   | 038  | Hexagon Socket Pan Head Cap Bolt M8x15 (S6)    | 8   |
| 015  | Wave Washer Ø28xØ17x0.3                        | 2   | 039  | Powder Metal Bushing<br>Ø14.2xØ10.2x10         | 4   |
| 016  | Powder Metal Bushing<br>Ø24.5xØ16x14           | 4   | 040  | Hexagon Socket Pan Head Cap Bolt M8x20 (S6)    | 2   |
| 017  | Spring Washer Ø20                              | 2   | 041  | Spring Washer Ø8                               | 8   |
| 018  | Hexagon Socket Pan Head Cap Bolt M8x10         | 1   | 042  | Washer Ø38x3                                   | 2   |
| 019  | Washer Ø40xØ24x3T                              | 1   | 043  | Powder Metal Bushing<br>Ø38xØ32xØ19x14         | 4   |

# PARTS LIST

| No.  | Description                                    | Qty | No. | Description                                    | Qty |
|------|--|-----|-----|--|-----|
| 044  | Carriage Bolt M6x35                            | 4   | 065 | Sensor with Wire (L=1600 mm)                   | 1   |
| 045  | Curve Washer Ø6xØ12x1.0T                       | 4   | 066 | Cross Recessed Pan Head Tapping Screw ST2.9x12 | 2   |
| 046  | Big Washer Ø8                                  | 2   | 067 | Left Cover                                     | 1   |
| 047  | Cross Recessed Pan Head Bolt M6x10             | 1   | 068 | Right Cover                                    | 1   |
| 048  | Plastic Bushing Ø32x69                         | 2   | 069 | Bearing Cup Ø51.5                              | 2   |
| 049L | Left Handrail Arm Cover-A                      | 1   | 070 | Ball Bearing                                   | 2   |
| 049R | Right Handrail Arm Cover-A                     | 1   | 071 | Bearing Nut I 15/16"                           | 1   |
| 050L | Left Handrail Arm Cover-B                      | 1   | 072 | Bearing Nut II 7/8"                            | 1   |
| 050R | Right Handrail Arm Cover-B                     | 1   | 073 | Washer Ø23xØ34.5x2.5                           | 1   |
| 051  | Tension Control Knob                           | 1   | 074 | Hexagon Nut 7/8"                               | 1   |
| 052  | Cross Recessed Pan Head Tapping Screw ST4.2x20 | 4   | 075 | Belt Pulley with Crank                         | 1   |
| 053  | Computer (XLG-505)                             | 1   | 076 | Hexagon Socket Pan Head Cap Bolt M8x25         | 1   |
| 054  | Rear Decorative Cover for Front Post           | 1   | 077 | Nut M10x1.0                                    | 2   |
| 055  | Hand Pulse Sensor with Wire L=750 mm           | 2   | 078 | Flywheel                                       | 1   |
| 056  | Handrail Foam Grip Ø31xØ37x480                 | 2   | 079 | Belt (PJ400/J6)                                | 1   |
| 057  | Handlebar Foam Grip Ø27xØ33x360                | 2   | 080 | Idler Arm                                      | 1   |
| 058  | Handrail End Cap Ø32                           | 2   | 081 | Cross Recessed Pan Head Bolt M6x15             | 2   |
| 059  | Handlebar End Cap Ø28                          | 2   | 082 | Eyebolt M6x36                                  | 2   |
| 060  | Screw ST4.2x25                                 | 8   | 083 | Tension Bracket                                | 2   |
| 061  | Curve Washer Ø20xØ5.2                          | 1   | 084 | Spring Washer Ø6                               | 2   |
| 062  | Cross Recessed Pan Head Bolt M5x55             | 1   | 085 | Nut M6   | 2   |
| 063  | Adjustable Leveler M10                         | 2   | 086 | Powder Metal Bushing Ø18xØ8x5                  | 4   |
| 064  | Extension Sensor Wire (L=1100 mm)              | 1   | 087 | Nut M10xH5                                     | 2   |

# PARTS LIST

| No. | Description                           | Qty | No. | Description                                    | Qty |
|-----|---------------------------------------|-----|-----|--|-----|
| 088 | Cross Recessed Pan Head Bolt M5x10    | 4   | 094 | Cross Recessed Pan Head Tapping Screw ST4.2x12 | 8   |
| 089 | Bearing 6000-2Z                       | 2   | 095 | Rubber Cover                                   | 2   |
| 090 | Front Decorative Cover for Front Post | 1   | 096 | Screw ST4.2x20                                 | 12  |
| 091 | Left Plastic Cover                    | 1   | 097 | Washer Ø14xØ10x1.0T                            | 2   |
| 092 | Right Plastic Cover                   | 1   | 098 | Plastic Screw Anchor Ø8x32                     | 2   |
| 093 | Curve Washer Ø16xØ8                   | 2   |     |  |     |

# TOOLS



Allen Wrench S6  
1 PC



Allen Wrench S8  
1 PC

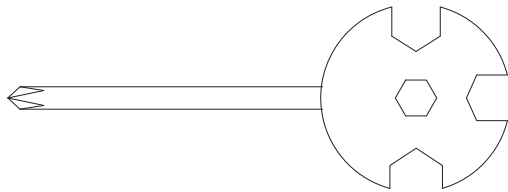

Multi Hex Tool with Phillips Screwdriver  
1 PC

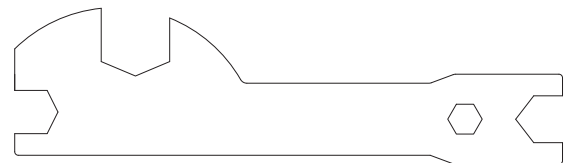

Multi Hex Tool  
1 PC

# HARDWARE LIST AND ASSEMBLY PART

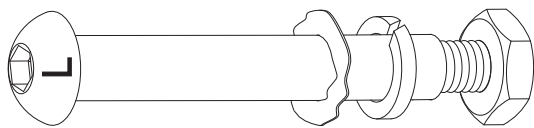

(13L) Bolt for left U-Shape Bracket 1 PC  
 (14L) Left Nylon Nut 1 PC  
 (15) Wave Washer 1 PC  
 (17) Spring Washer 1 PC

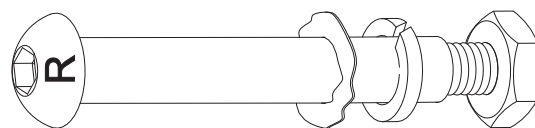

(13R) Bolt for right U-Shape Bracket 1 PC  
 (14R) Right Nylon Nut 1 PC  
 (15) Wave Washer 1 PC  
 (17) Spring Washer 1 PC

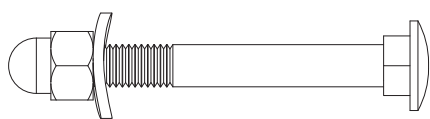

(9) Carriage Bolt 4 PCS  
 (11) Big Curve Washer 4 PCS  
 (12) Cap Nut 4 PCS

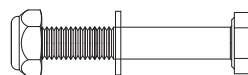

(24) Nylon Nut 6 PCS  
 (25) Washer 6 PCS  
 (26) Hexagon Head Bolt 6 PCS

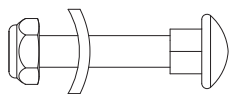

(24) Nylon Nut 4 PCS  
 (44) Carriage Bolt 4 PCS  
 (45) Curve Washer 4 PCS

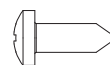

(94) Cross Recessed Pan  
 Head Tapping Screw  
 8 PCS

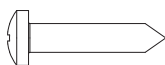

(96) Screw  
 8 PCS



(28) Bolt Cap  
 2 PCS



# EXPLODED VIEW

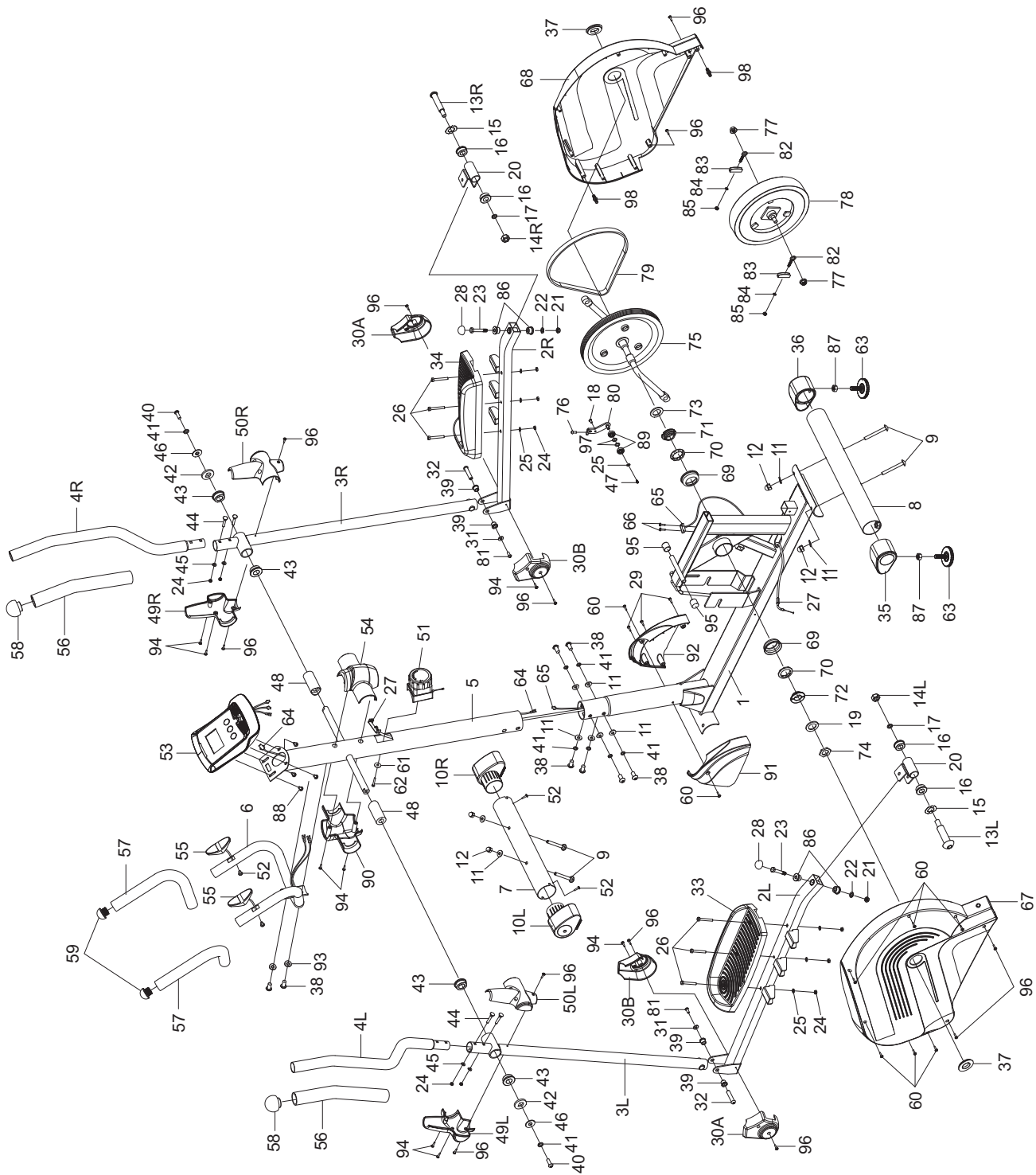

# ASSEMBLY INSTRUCTIONS

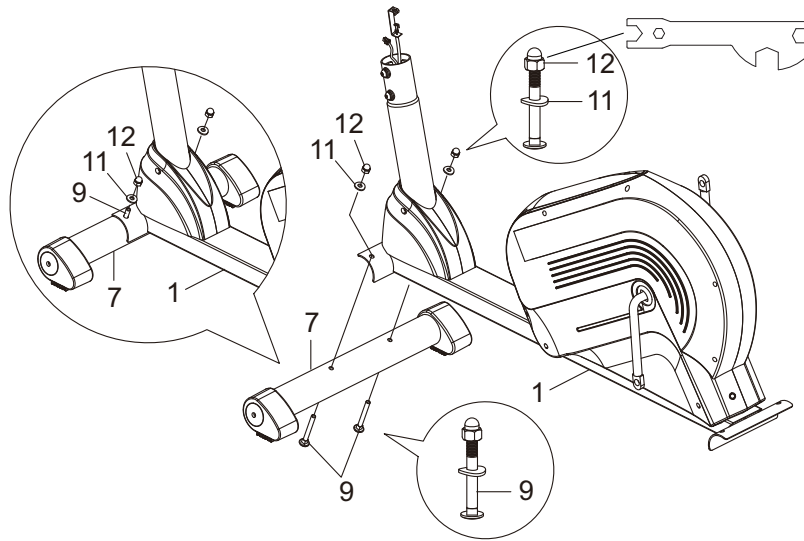

## STEP 1

Position the Front Stabilizer (7) in front of the Main Frame (1) and align bolt holes. Attach the Front Stabilizer (7) onto the front curve of the Main Frame (1) with two Carriage Bolts (9), two Big Curve Washers (11), and two Cap Nuts (12). Tighten cap nuts with the Multi Hex Tool provided.

## Hardware:

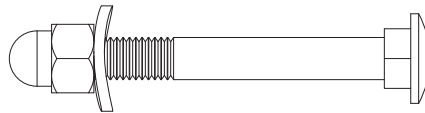

|                       |       |
|-----------------------|-------|
| (9) Carriage Bolt     | 2 PCS |
| (11) Big Curve Washer | 2 PCS |
| (12) Cap Nut          | 2 PCS |

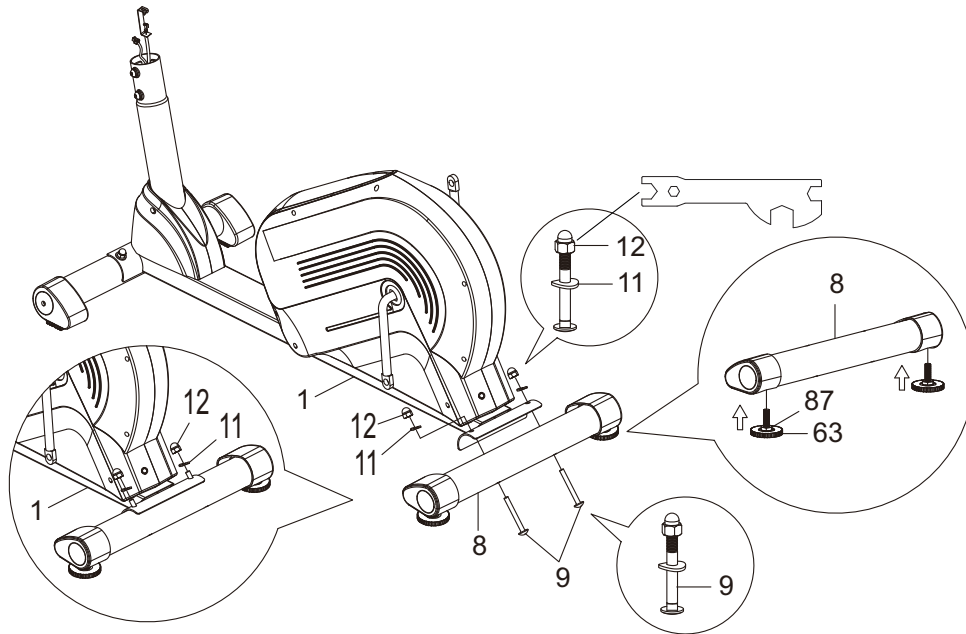

## STEP 2

Install two Adjustable Levelers (63) with two Nuts (87) onto the Rear Stabilizer (8). Position the Rear Stabilizer (8) behind the Main Frame (1) and align bolt holes. Attach the Rear Stabilizer (8) onto the rear curve of the Main Frame (1) with two Carriage Bolts (9), two Big Curve Washers (11), and two Cap Nuts (12). Tighten cap nuts with the Multi Hex Tool provided.

## Hardware:

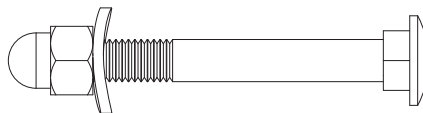

|                       |       |
|-----------------------|-------|
| (9) Carriage Bolt     | 2 PCS |
| (11) Big Curve Washer | 2 PCS |
| (12) Cap Nut          | 2 PCS |

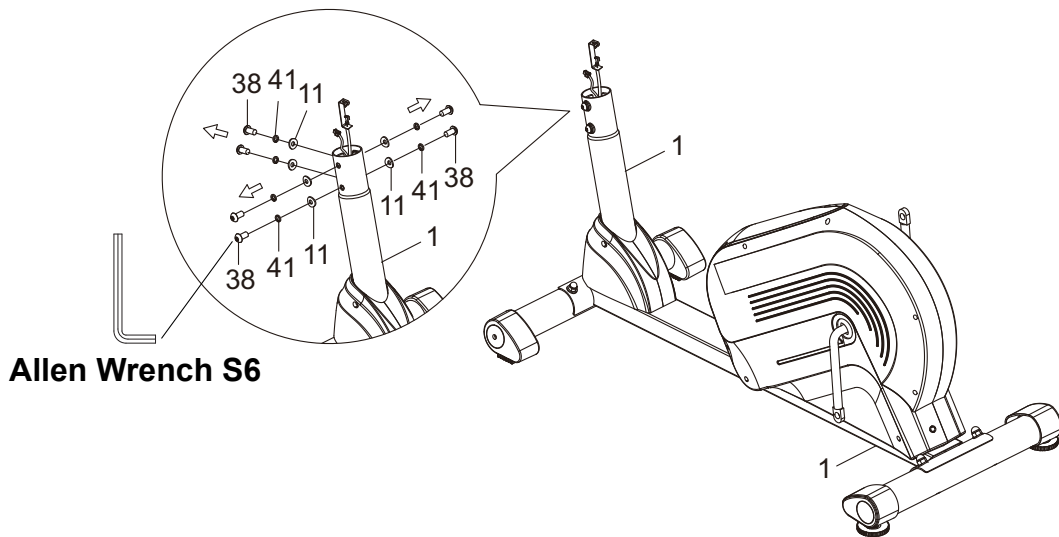

### STEP 3

Remove six Hexagon Socket Pan Head Cap Bolts (38), six Spring Washers (41), and six Big Curve Washers (11) from the Main Frame (1). Remove bolts with the S6 Allen Wrench provided.

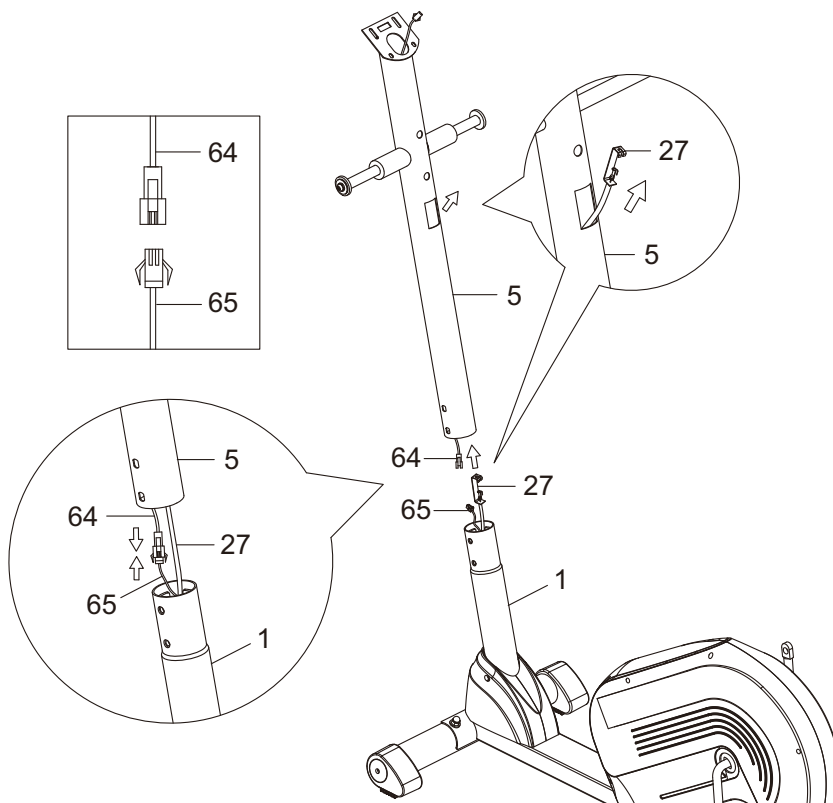

### STEP 4

It is recommended to have a second person assist with this step. One person should hold the Front Post (5) in place while the other person to connect the wires.

Insert the Tension Cable (27) through into the bottom hole of the Front Post (5) and pull it out from the square hole of the Front Post (5).

Connect the Sensor Wire (65) from the Main Frame (1) to the Extension Sensor Wire (64) from the Front Post (5).

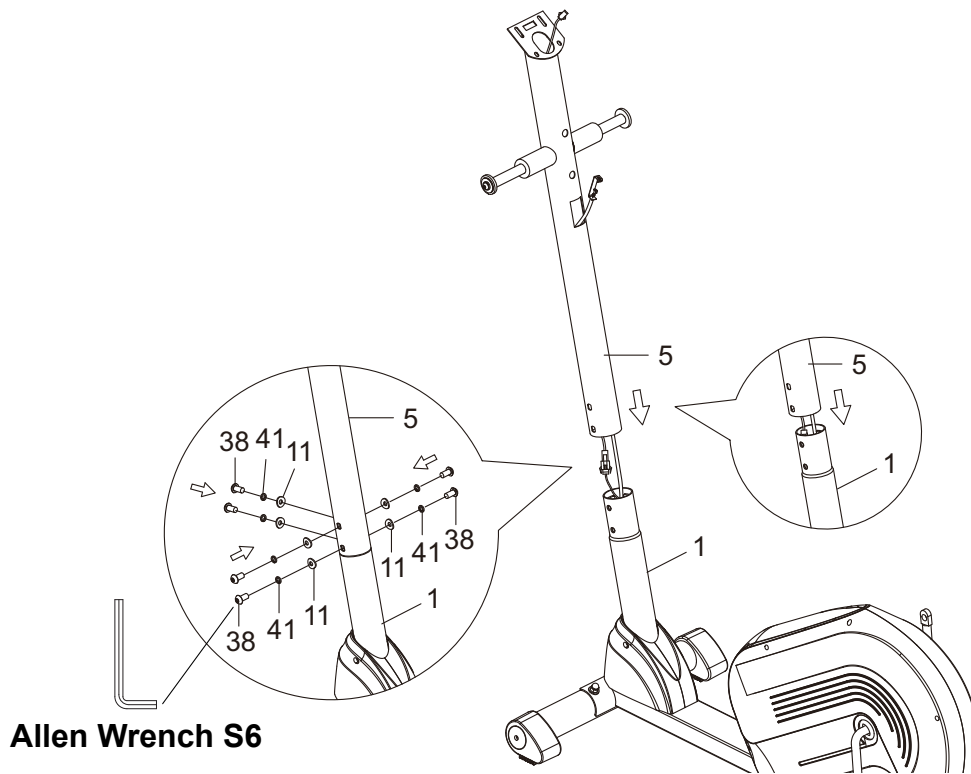

### STEP 5

Insert the Front Post (5) onto the tube of the Main Frame (1) and secure with six Hexagon Socket Pan Head Cap Bolts (38), six Spring Washers (41), and six Big Curve Washers (11) that were removed. Tighten bolts with the S6 Allen Wrench provided.

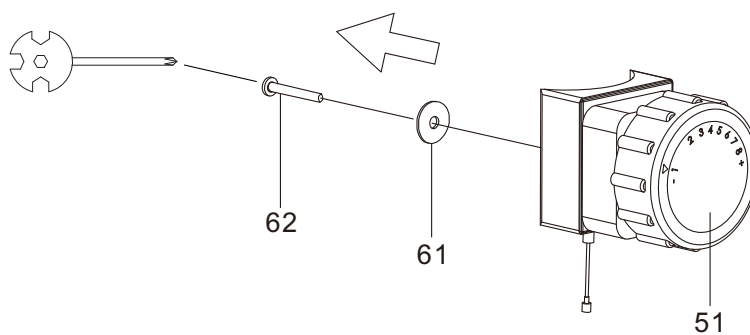

### STEP 6

Remove one Cross Recessed Pan Head Bolt (62) and one Curve Washer (61) from the Tension Control Knob (51). Remove bolt with the Multi Hex Tool with Phillips Screwdriver provided.

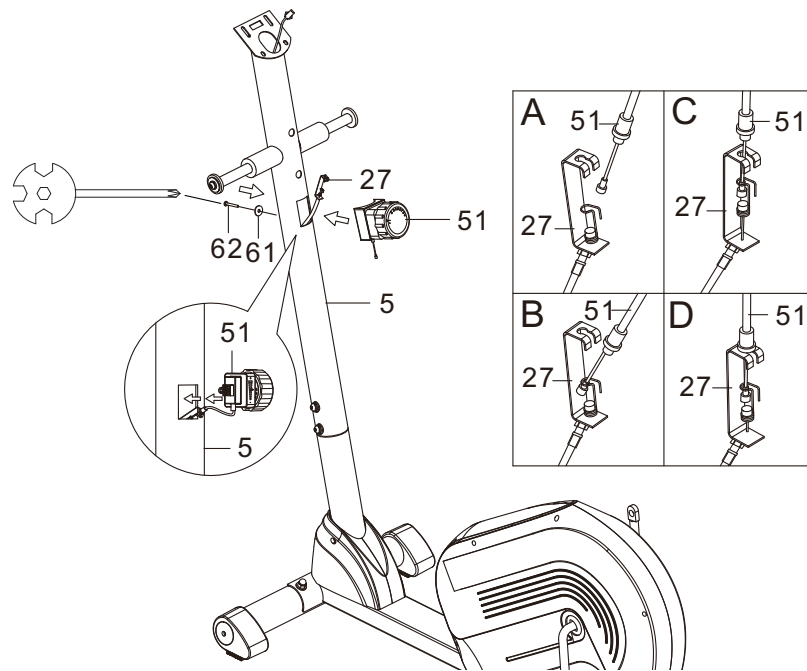

### STEP 7

Put the cable end of resistance cable of Tension Control Knob (51) into the cable lock of Tension Cable (27), see Figure A.

Pull the resistance cable of Tension Control Knob (51) up and force it into the slot of metal bracket of Tension Cable (27), see Figure B.

Insert the metal fitting on the resistance cable of Tension Control Knob (51) into the hole at the end of the slot in the metal bracket of Tension Cable (27), see Figure C.

Connect the resistance cable of Tension Control Knob (51) to Tension Cable (27) complete, see Figure D.

Attach the Tension Control Knob (51) onto the Front Post (5) with one Cross Recessed Pan Head Bolt (62) and one Curve Washer (61) that were removed. Tighten bolt with the Multi Hex Tool with Phillips Screwdriver provided.

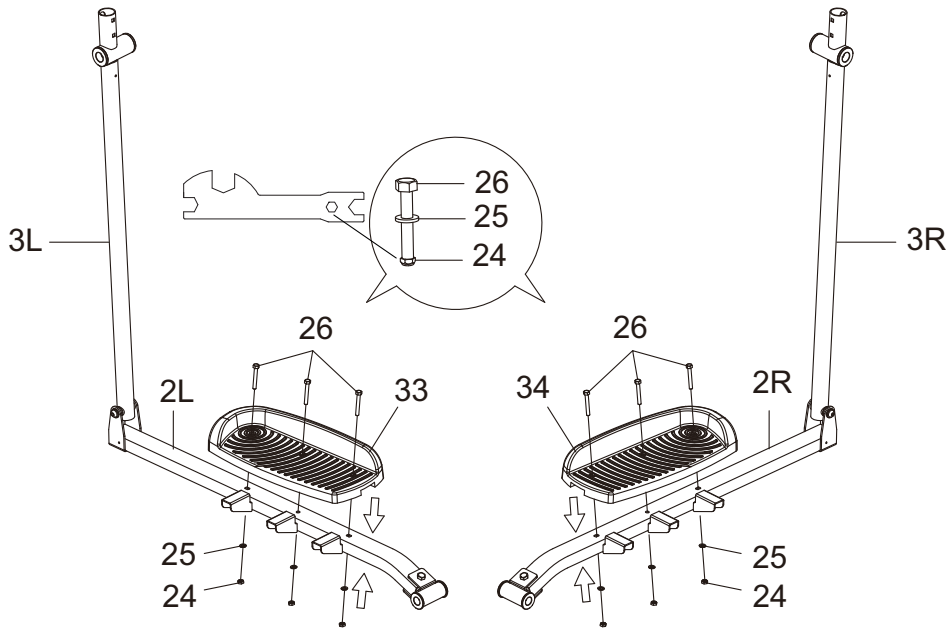

### STEP 8

Attach the Left Foot Pedal (33) onto the Left Foot Bar (2L) with three Hexagon Head Bolts (26), three Washers (25), and three Nylon Nuts (24). Tighten the nylon nuts with the Multi Hex Tool provided.

Attach the Right Foot Pedal (34) onto the Right Foot Bar (2R) with three Hexagon Head Bolts (26), three Washers (25), and three Nylon Nuts (24). Tighten the nylon nuts with the Multi Hex Tool provided.

### Hardware:

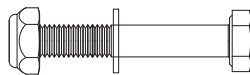

|                        |       |
|------------------------|-------|
| (24) Nylon Nut         | 6 PCS |
| (25) Washer            | 6 PCS |
| (26) Hexagon Head Bolt | 6 PCS |

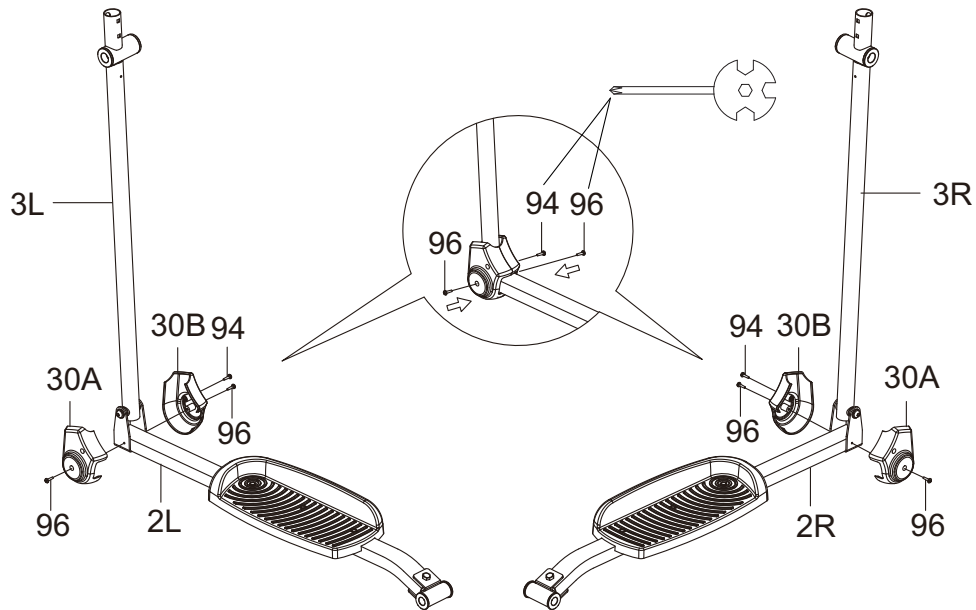

### STEP 9

Attach two Foot Bar Covers-A (30A) and two Foot Bar Covers-B (30B) onto the front end of the Left and Right Foot Bars (2L, 2R) with two Cross Recessed Pan Head Tapping Screws (94) and four Screws (96). Tighten screws with the Multi Hex Tool with Phillips Screwdriver provided.

### Hardware:

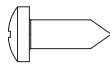

(94) Cross Recessed Pan  
Head Tapping Screw  
2 PCS



(96) Screw  
4 PCS



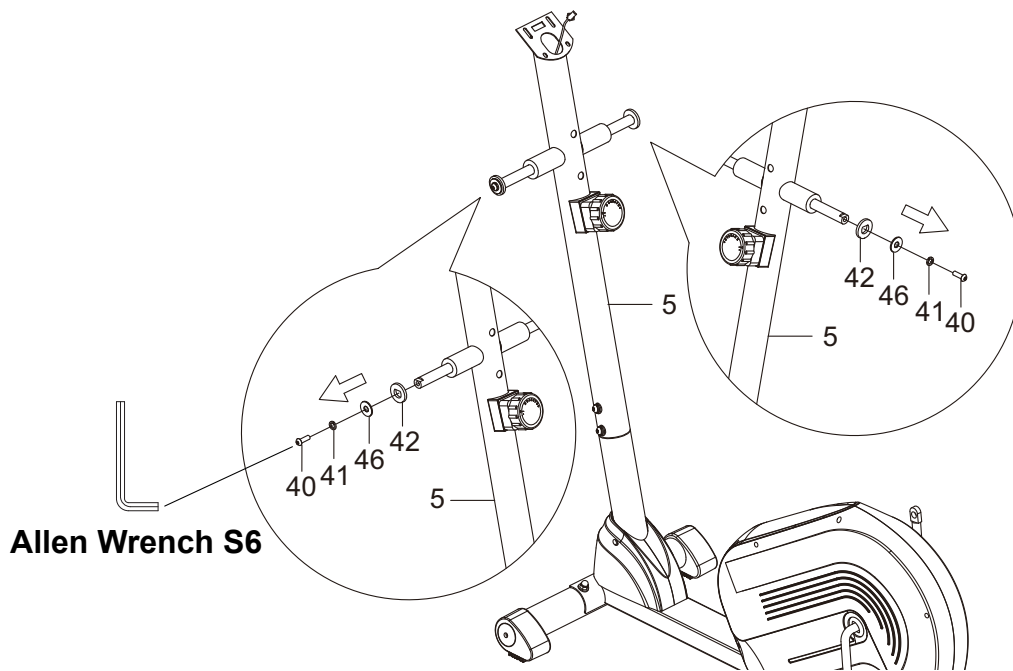

### STEP 10

Remove two Hexagon Socket Pan Head Cap Bolts (40), two Spring Washers (41), two Big Washers (46), and two Washers (42) from the right and right horizontal axes of the Front Post (5). Remove bolts with the S6 Allen Wrench provided.

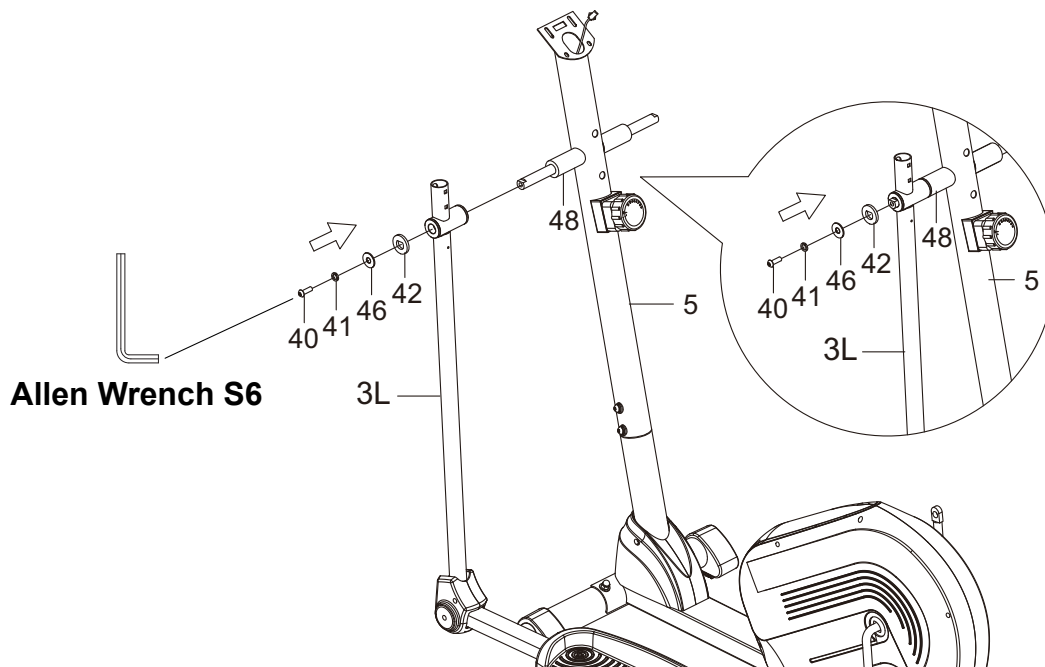

### STEP 11

Attach the Left Handrail Arm (3L) onto the left horizontal axis of the Front Post (5) with one Hexagon Socket Pan Head Cap Bolt (40), one Spring Washer (41), one Big Washer (46), and one Washer (42) that were removed. Tighten bolts with the S6 Allen Wrench provided.

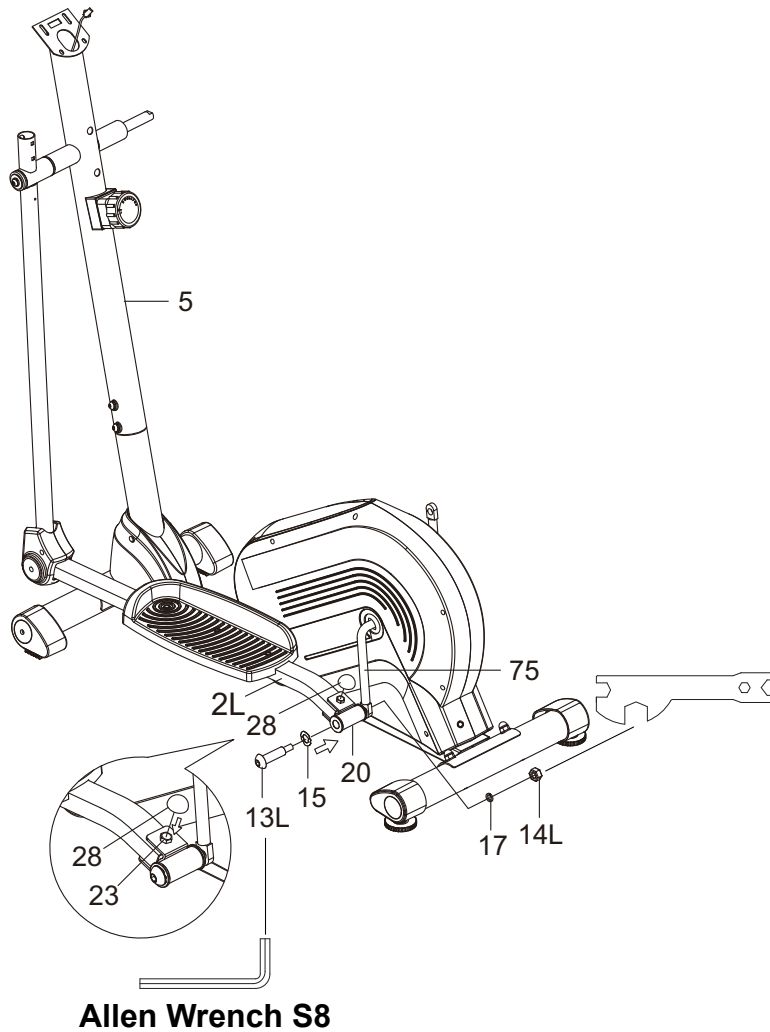

**STEP 12**

Attach the U-Shape Bracket (20) onto the left Crank (75) with one Bolt for left U-Shape Bracket (13L), one Wave Washer (15), one Spring Washer (17), and one Left Nylon Nut (14L). Tighten bolt and nylon nut with the S8 Allen Wrench and Multi Hex Tool provided. Install one Bolt Cap (28) onto the Hexagon Head Bolt (23).

**Hardware & Assembly Part:**

**Bolt is marked "L" for Left.**

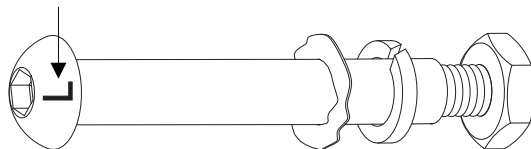

- (13L) Bolt for left U-Shape Bracket 1 PC
- (14L) Left Nylon Nut 1 PC
- (15) Wave Washer 1 PC
- (17) Spring Washer 1 PC

- (28) Bolt Cap 1 PC

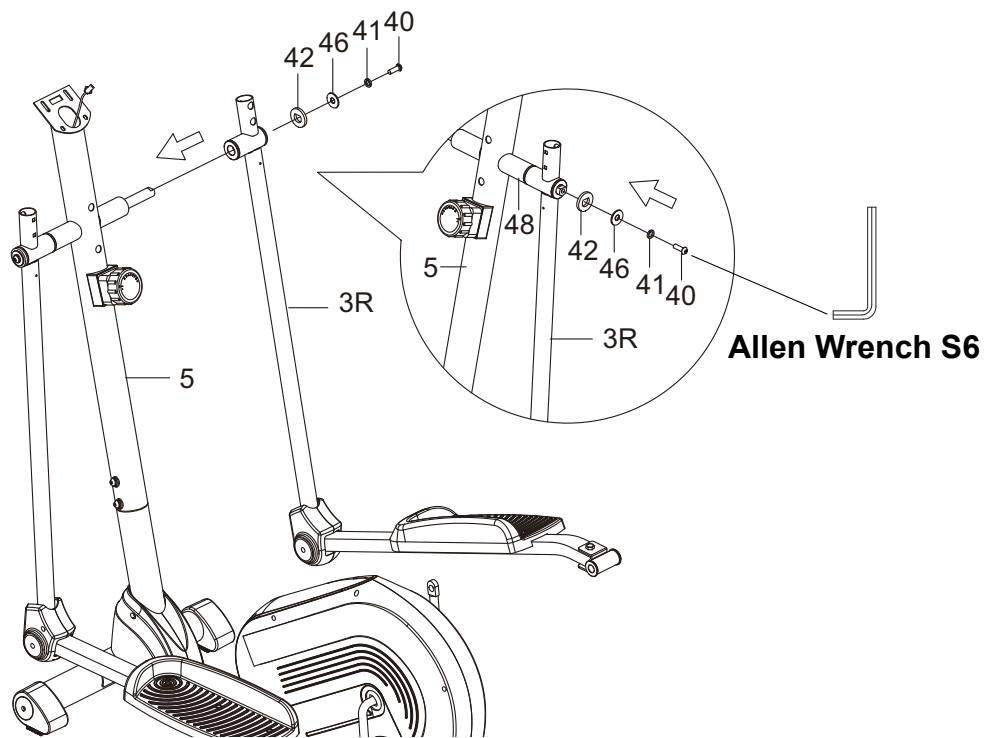

### STEP 13

Attach the Right Handrail Arm (3R) onto the right horizontal axis of the Front Post (5) with one Hexagon Socket Pan Head Cap Bolt (40), one Spring Washer (41), one Big Washer (46), and one Washer (42) that were removed. Tighten bolts with the S6 Allen Wrench provided.

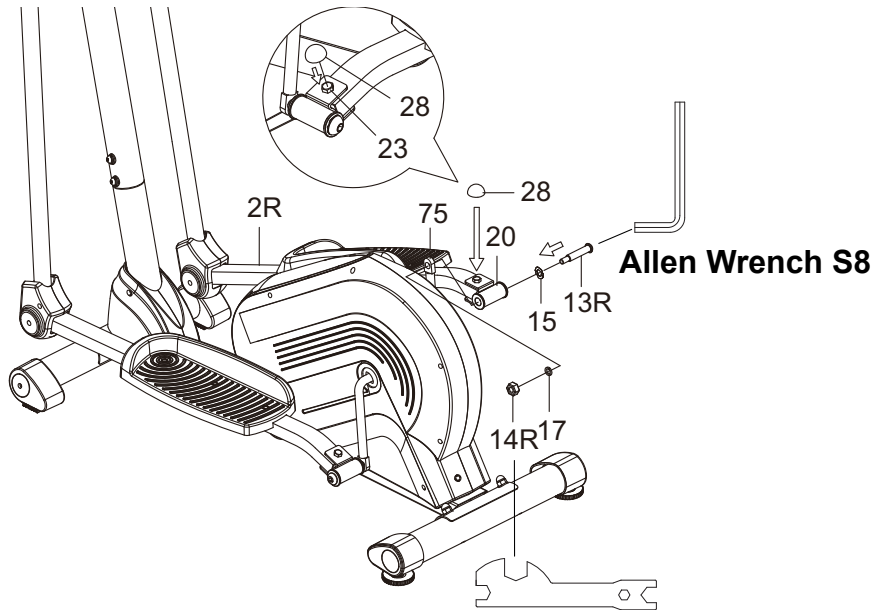

**STEP 14**

Attach the U-Shape Bracket (20) onto the right Crank (75) with one Bolt for right U-Shape Bracket (13R), one Wave Washer (15), one Spring Washer (17), and one Right Nylon Nut (14R). Tighten bolt and nylon nut with the S8 Allen Wrench and Multi Hex Tool provided. Install one Bolt Cap (28) onto the Hexagon Head Bolt (23).

**Hardware & Assembly Part:**

Bolt is marked "R" for Right.

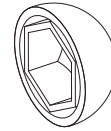
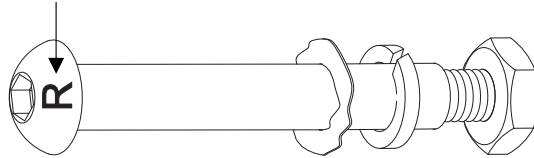

- (13R) Bolt for right U-Shape Bracket      1 PC
- (14R) Right Nylon Nut                              1 PC
- (15) Wave Washer                                      1 PC
- (17) Spring Washer                                    1 PC

- (28) Bolt Cap  
1 PC

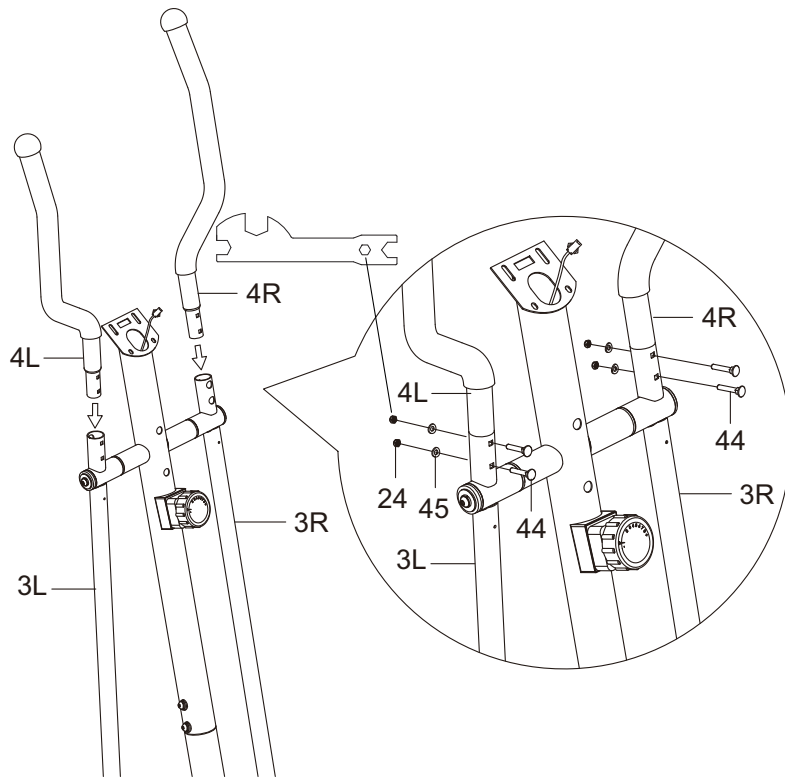

### STEP 15

Attach both Right and Left Handrails (4R, 4L) into the top ends of both Right and Left Handrail Arms (3R, 3L) with four Carriage Bolts (44), four Curve Washers (45), and four Nylon Nuts (24). Tighten nylon nuts with the Multi Hex Tool provided.

### Hardware:

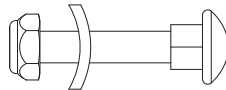

|                    |       |
|--------------------|-------|
| (24) Nylon Nut     | 4 PCS |
| (44) Carriage Bolt | 4 PCS |
| (45) Curve Washer  | 4 PCS |

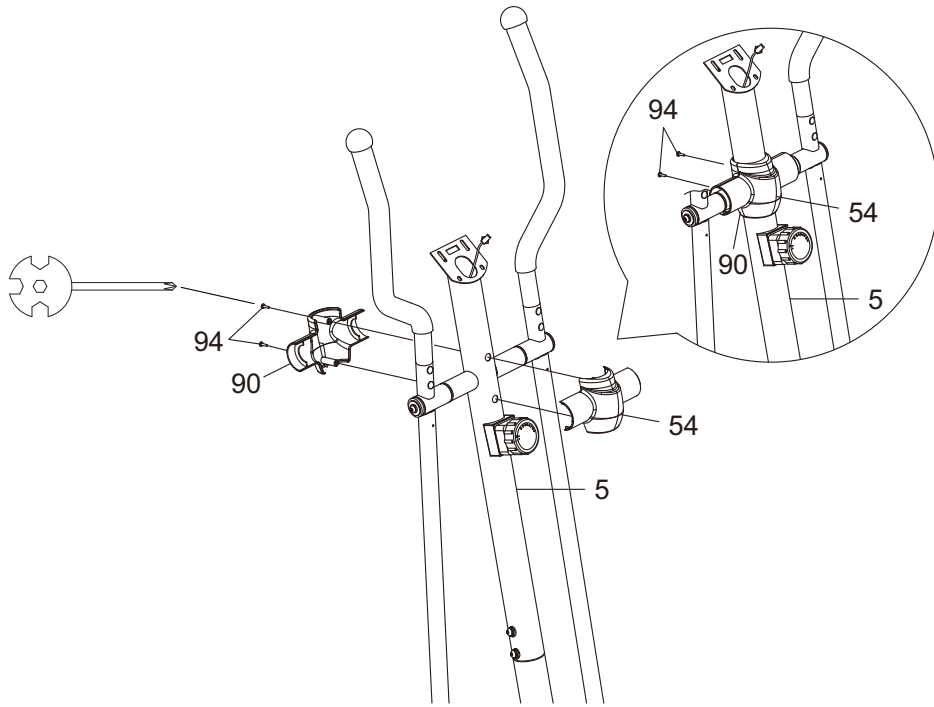

**STEP 16**

Attach the Front Decorative Cover for Front Post (90) and Rear Decorative Cover for Front Post (54) onto the Front Post (5) with two Cross Recessed Pan Head Tapping Screws (94). Tighten screws with the Multi Hex Tool with Phillips Screwdriver provided.

**Hardware:**

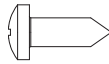

(94) Cross Recessed Pan  
Head Tapping Screw  
2 PCS

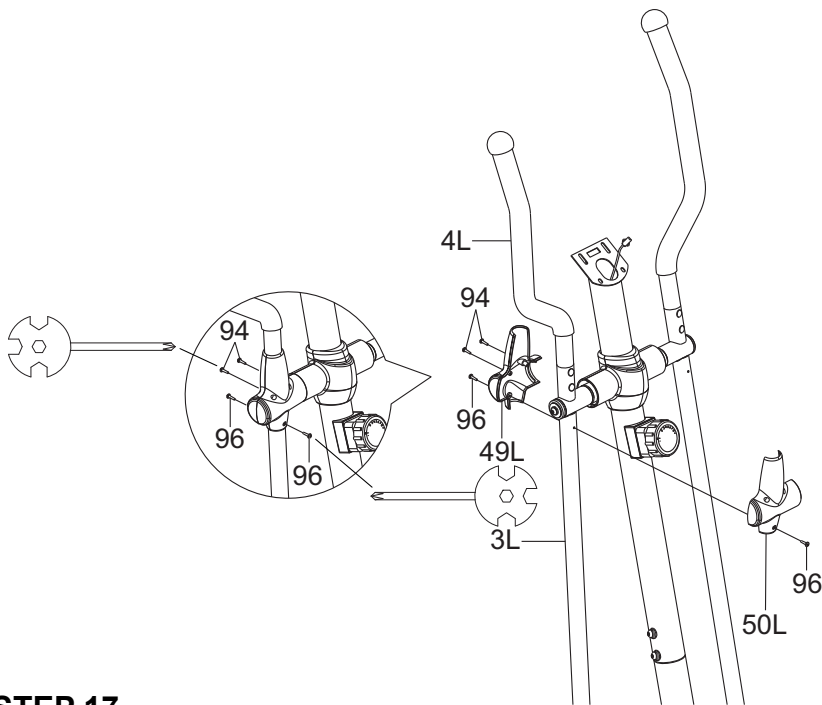

**Hardware:**

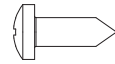

(94) Cross Recessed Pan Head Tapping Screw  
2 PCS



(96) Screw  
2 PCS

**STEP 17**

Attach the Left Handrail Arm Cover-A (49L) and Left Handrail Arm Cover-B (50L) onto the Left Handrail Arm (3L) with two Cross Recessed Pan Head Tapping Screws (94) and two Screws (96). Tighten screws with the Multi Hex Tool with Phillips Screwdriver provided.

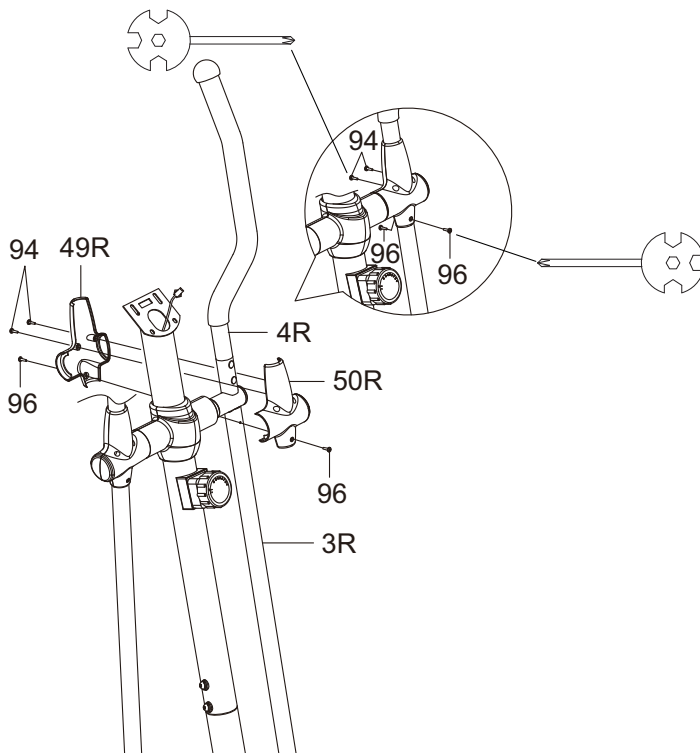

**Hardware:**

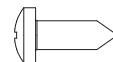

(94) Cross Recessed Pan Head Tapping Screw  
2 PCS

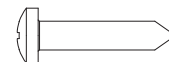

(96) Screw  
2 PCS

**STEP 18**

Attach the Right Handrail Arm Cover-A (49R) and Right Handrail Arm Cover-B (50R) onto the Left Handrail Arm (3R) with two Cross Recessed Pan Head Tapping Screws (94) and two Screws (96). Tighten screws with the Multi Hex Tool with Phillips Screwdriver provided.

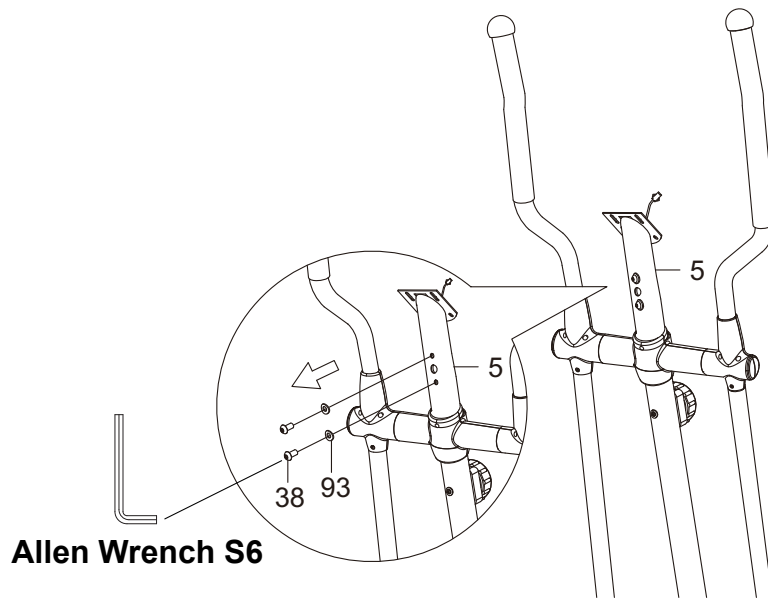

### STEP 19

Remove two Hexagon Socket Pan Head Cap Bolts (38) and two Curve Washers (93) from the Front Post (5). Remove bolts with the S6 Allen Wrench provided.

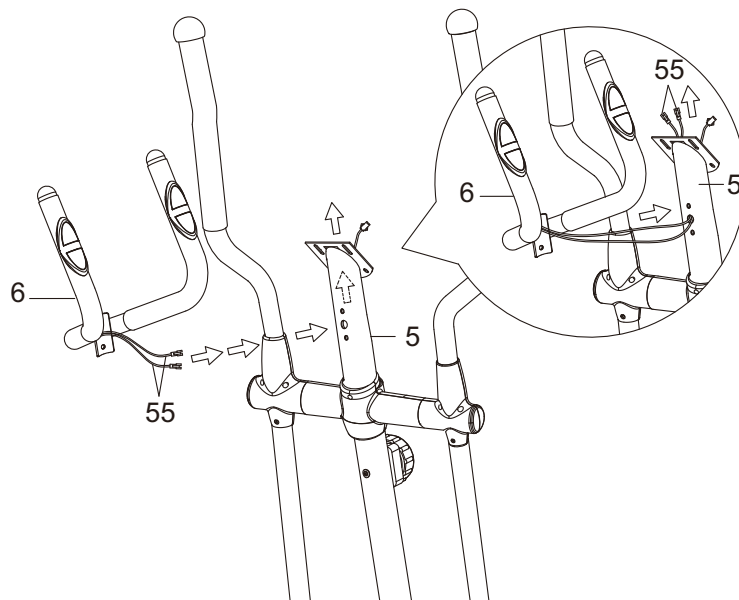

### STEP 20

Insert the Hand Pulse Sensor Wires (55) from the Handlebar (6) into the hole on the Front Post (5) and then pull them out from the top end of the Front Post (5).



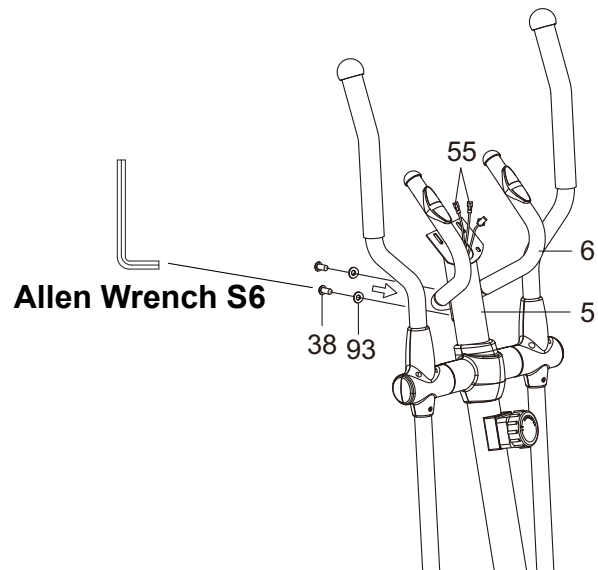

**STEP 21**

Attach the Handlebar (6) onto the Front Post (5) with two Hexagon Socket Pan Head Cap Bolts (38) and two Curve Washers (93) that were removed. Tighten bolts with the S6 Allen Wrench provided.

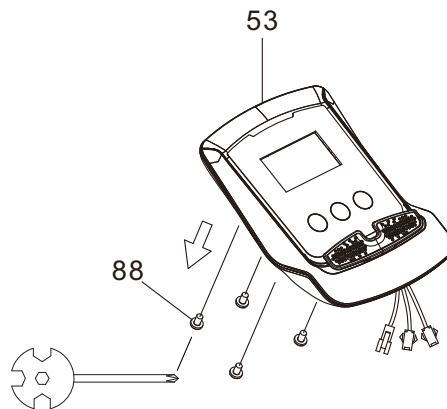

**STEP 22**

Remove four Cross Recessed Pan Head Bolts (88) from the Computer (53). Remove bolts with the Multi Hex Tool with Phillips Screwdriver provided.

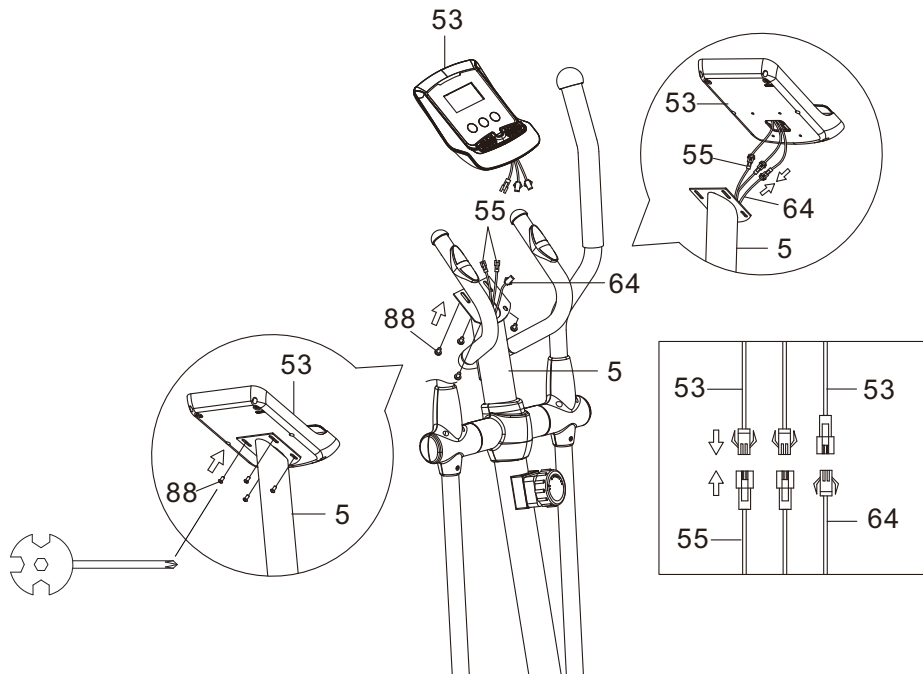

### STEP 23

It is recommended to have a second person assist with this step. One person should hold the Computer (53) in place while the other person to connect the wires. Connect the Hand Pulse Sensor Wires (55) and Extension Sensor Wire (64) to the wires that come from the Computer (53). Tuck wires into the Front Post (5). Attach the Computer (53) onto the top end of the Front Post (5) with four Cross Recessed Pan Head Bolts (88) that were removed. Tighten bolts with the Multi Hex Tool with Phillips Screwdriver provided.

# HOW TO MOVE THE ELLIPTICAL TRAINER

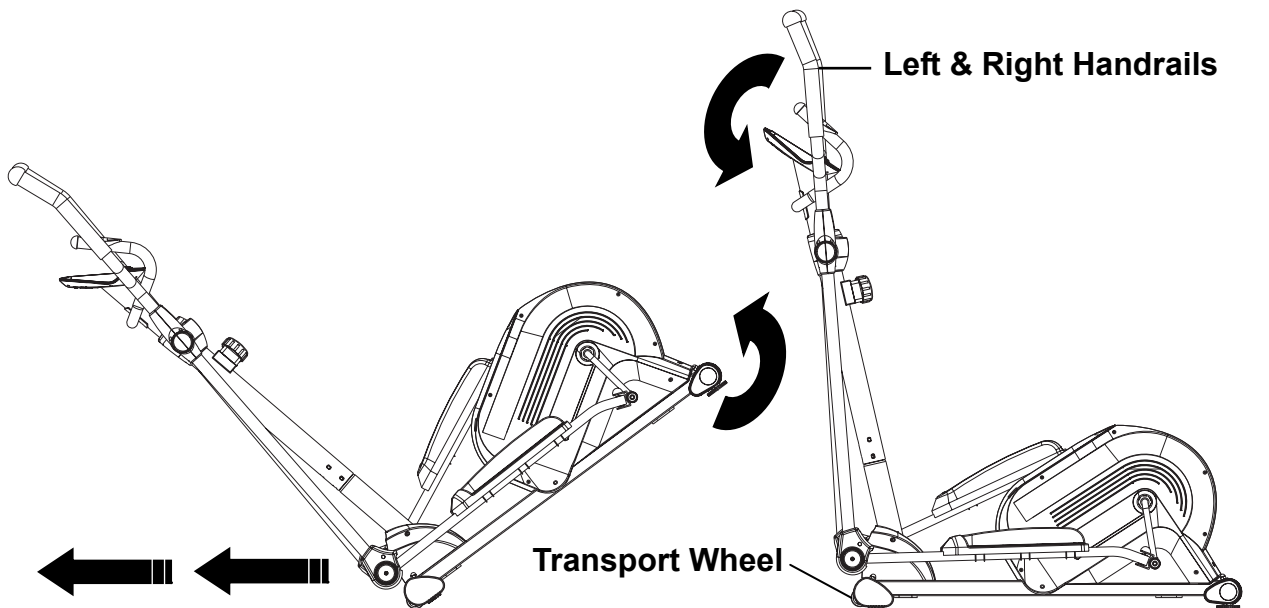

This elliptical trainer has a pair of Transport Wheels built into the front stabilizer and can be carefully tilted onto its Transport Wheels for easy moving and storage. Stand in front of the unit and grasp the Left and Right Handrails with both hands, then push or pull both handrails to make them parallel. Next, carefully push the elliptical trainer down until it rolls freely on the Transport Wheels.

**CAUTION:** It is suggested you always use the aid of a second person when moving the elliptical trainer.

# OPERATING THE COMPUTER

## USING YOUR COMPUTER

The computer can be activated by pressing one of the three buttons or by pedaling. If you leave the equipment idle for 4 minutes, the power will turn off automatically.



## BUTTON FUNCTIONS:

**MODE:** Press the MODE button to select the functions of the computer. Press and hold the MODE button for 3 seconds to reset all data values to zero except the TOTAL data values.

**SET:** Press the SET button to set data values of TMR (TIMER), DST (DISTANCE), or CAL (CALORIES) for target pre-setting.

**RESET:** Press the RESET button to reset data values of TMR (TIMER), DST (DISTANCE), or CAL (CALORIES) to zero.

Press and hold the RESET button for 3 seconds to reset all data values to zero except the TOTAL data values.

## COMPUTER FUNCTIONS:

**SCAN:** Press the MODE button until the screen displays SCAN, the computer will automatically scan each function in sequence with change every 6 seconds.

**TMR (TIMER):** Displays your elapsed workout time in minutes and seconds. You may also pre-set target time in STOP mode before training. To set TIMER press the MODE button until the screen displays TMR. Press the SET button to change the time, each time you press the SET button time should change by 1 minute. Press the RESET button to clear the target time to zero. The pre-set target time range is from 0:00 to 99:00 minutes. Once you pre-set target time and then start to exercise, time starts counting down from pre-set target time to 0:00 per 1 second backward. When the pre-set target time counts down to 0:00, time will start to count up immediately and the computer will begin beeping to remind you.

**SPD (SPEED):** Displays the current training speed.

**DST (DISTANCE):** Displays the cumulative distance travelled during workout. You may also pre-set target distance in STOP mode before training. To set DISTANCE press the MODE button until the screen displays DST. Press the SET button to change the distance, each time you press the SET button distance should change by 0.1 km. Press the RESET button to clear the target distance to zero. The pre-set target distance range is from 0.0 to 99.90 km. Once you pre-set target distance and then start to exercise, distance starts counting down from pre-set target distance to 0.0. When the pre-set target distance counts down to 0.0, distance will start to count up immediately and the computer will begin beeping to remind you.

**CAL (CALORIES):** Displays approximate amount of calories burned during workout. You may also pre-set target calories in STOP mode before training. To set CALORIES press the MODE button until the screen displays CAL. Press the SET button to change the calories, each time you press the SET button calories should change by 1.0 calorie. Press the RESET button to clear the target calories to zero. The pre-set target calories range is from 0.0 to 999.0 calories. Once you pre-set target calories and then start to exercise, calories start counting down from pre-set target calories to 0.0. When the pre-set target calories count down to 0.0, calories will start to count up immediately and the computer will begin beeping to remind you. (This data is a rough guide for comparison of different exercise sessions and should not be used in medical treatment).

**TOTAL:** Displays the total accumulative distance travelled. The TOTAL data values can not be reset to zero by pressing and holding the MODE or RESET button for 3 seconds. If you take out the batteries from the computer, the TOTAL data values will reset to zero.

**PULSE:** Displays your current heart rate figures after you grip the handlebar pulse sensors with both your hands during exercise. To ensure the pulse readout is more precise, please always hold on to the handlebar pulse sensors with two hands instead of just with one hand only when you try to test your heart rate figures.

#### **HOW TO INSTALL THE BATTERIES:**

1. Remove the battery cover on the back of the computer.
2. Place two size AA batteries into the battery housing.
3. Insure batteries are correctly positioned and battery springs are in proper contact with batteries.
4. Re-install the battery cover.
5. If the display is illegible or only partial segment appears, remove batteries and wait 15 seconds before reinstalling.

# ADJUSTMENTS

## Adjusting the Tension Control Knob

To increase the tension, turn the tension control knob  
In a clockwise direction.

To decrease the tension, turn the tension control knob  
in a counterclockwise direction.

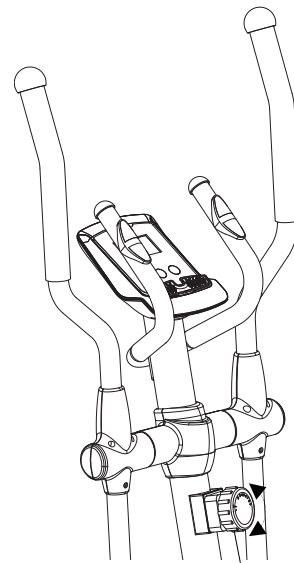

**Tension Control Knob**

## Adjusting the Adjustable Leveler

Turn the adjustable leveler on the rear stabilizer as  
needed to level the elliptical trainer.

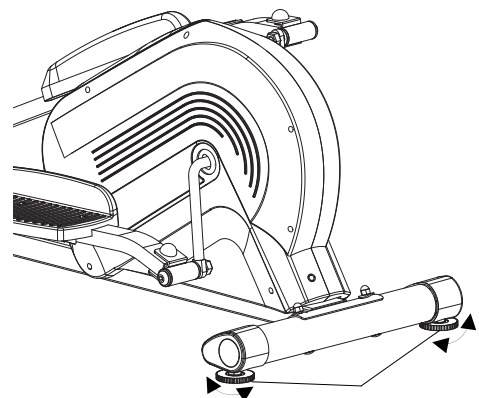

**Adjustable Leveler**

# MAINTENANCE

## Cleaning

The elliptical trainer can be cleaned with a soft clean damp cloth. Do not use abrasives or solvents on plastic parts. Please wipe your perspiration off the elliptical trainer after each use. Be careful not to get excessive moisture on the computer display panel as this might cause an electrical hazard or electronics to fail.

Please keep the elliptical trainer, especially the computer console out of direct sunlight to prevent screen damage.

Please inspect all assembly bolts, nuts, screws, and pedals on the machine for proper tightness every week.

## Storage

Store the elliptical trainer in a clean and dry environment away from children.

# TROUBLESHOOTING

| PROBLEM   | SOLUTION   |
|---|--|
| The elliptical trainer wobbles when in use.                                     | Turn the adjustable leveler on the rear stabilizer as needed to level the elliptical trainer.  |
| There is no display on the computer console.                                    | <ol style="list-style-type: none"> <li>1. Remove the computer console and verify the wires that come from the computer console are properly connected to the wires that come from the front post.</li> <li>2. Check if the batteries are correctly positioned and battery springs are in proper contact with batteries.</li> <li>3. The batteries in the computer console may be dead. Replace with new batteries.</li> </ol>  |
| There is no heart rate reading or heart rate reading is erratic / inconsistent. | <ol style="list-style-type: none"> <li>1. Make sure that the wire connections for the hand pulse sensors are secure.</li> <li>2. To ensure the pulse readout is more precise, please always hold on to the handlebar grip sensors with both hands instead of just with one hand when you try to test your heart rate figures.</li> <li>3. Avoid gripping the hand pulse sensors too tight. Try to maintain moderate pressure while holding onto the hand pulse sensors.</li> </ol> |
| The elliptical trainer makes a squeaking noise when in use.                     | The bolts may be loose on the elliptical trainer. Please inspect all of the bolts and tighten any loose bolts.   |

# WARM UP AND COOL DOWN ROUTINE

The **WARM-UP** is an important part of any workout. The purpose of warming up is to prepare your body for exercise and to minimize injuries. Warm up for two to five minutes before aerobic exercising. It should begin every session to prepare your body for more strenuous exercise by heating up and stretching your muscles, increasing your circulation and pulse rate, and delivering more oxygen to your muscles.

**COOL DOWN** at the end of your workout, repeat these exercises to reduce soreness in tired muscles. The purpose of cooling down is to return the body to its resting state at the end of each exercise session. A proper cool-down slowly lowers your heart rate and allows blood to return to the heart.

## HEAD ROLLS

Rotate your head to the right for one count, you should feel a stretching sensation up the left side of your neck. Then rotate your head back for one count, stretching your chin to the ceiling and letting your mouth open. Rotate your head to the left for one count, then drop your head to your chest for one count.

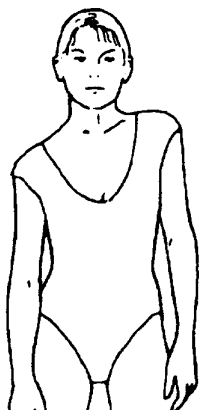

## SHOULDER LIFTS

Lift your right shoulder toward your ear for one count. Then lift your left shoulder up for one count as you lower your right shoulder.

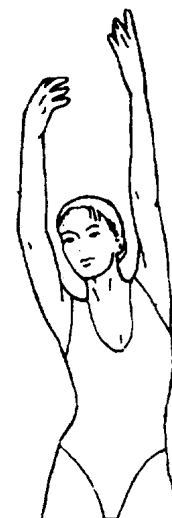

## SIDE STRETCHES

Open your arms to the side and lift them until they are over your head. Reach your right arm as far toward the ceiling as you can for one count. Repeat this action with your left arm.





### **QUADRICEPS STRETCH**

With one hand against a wall for balance, reach behind you and pull your right foot up. Bring your heel as close to your buttocks as possible. Hold for 15 counts and repeat with left foot.

### **INNER THIGH STRETCH**

Sit with the soles of your feet together and your knees pointing outward. Pull your feet as close to your groin as possible. Gently push your knees toward the floor. Hold for 15 counts.

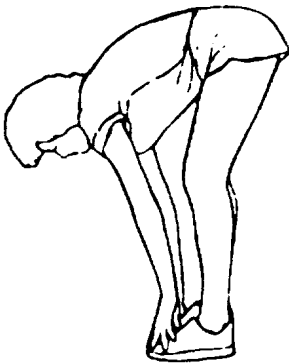

### **TOE TOUCHES**

Slowly bend forward from your waist, letting your back and shoulders relax as you stretch toward your toes. Reach as far as you can and hold for 15 counts.

### **HAMSTRING STRETCHES**

Extend your right leg. Rest the sole of your left foot against your right inner thigh. Stretch toward your toe as far as possible. Hold for 15 counts. Relax and then repeat with left leg.

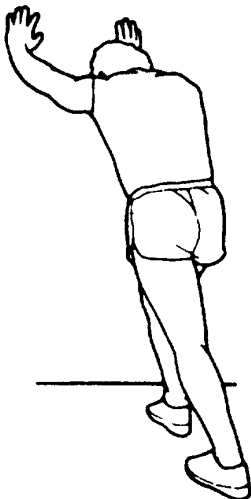
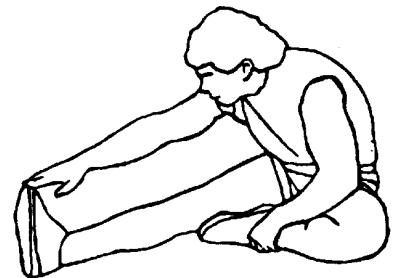

### **CALF/ACHILLES STRETCH**

Lean against a wall with your left leg in front of the right and your arms forward. Keep your right leg straight and the left foot on the floor; then bend the left leg and lean forward by moving your hips toward the wall. Hold, then repeat on the other side for 15 counts.